

单级油旋片泵 SINGLE STAGE OIL ROTARY VANE VACUUM PUMP

产品特点/Product Features

- 无弹簧旋片，实现低噪音、低振动、高寿命；内置油逆止阀，大幅减少返油现象；
No spring coil, low noise, low vibration, high life; Built-in oil check valve, greatly reduce oil return phenomenon
- 风冷、油冷、水冷等多种冷却方式相结合，确保良好的冷却效果，实现产品长期稳定运行，抽空性能稳定；
The combination of air cooling, oil cooling, water cooling and other cooling methods ensures good cooling effect.
- 合理的产品结构，易拆装，维护保养快速便捷。
Reasonable product structure, easy to disassemble and assemble, fast and convenient maintenance.

RA0020/0040/0063/0100F



型号/Model	单位/Unit	RA0020F		RA0040F		RA0063F		RA0100F	
		50HZ	60HZ	50HZ	60HZ	50HZ	60HZ	50HZ	60HZ
抽速 Nominal Capacity	m ³ /h	20	25	40	48	63	76	100	120
极限真空 Ultimate pressure	mbar	0.5		0.5		0.5		0.5	
电机功率 Motor Power	KW	0.75		1.5		2.2		3.0	
电机转速 motor speed	rpm	2800	3300	1450	1740	1450	1740	1450	1740
噪音等级 Sound level	dB	60		62		65		70	
用油量 Oil filling	L	1.0		1.5		2.5		2.5	
接口尺寸 Interface Size		G3/4		G1 1/4		G1 1/4		G1 1/4	
重量 Weight	KG	20		40		55		75	

RA0020F size/mm

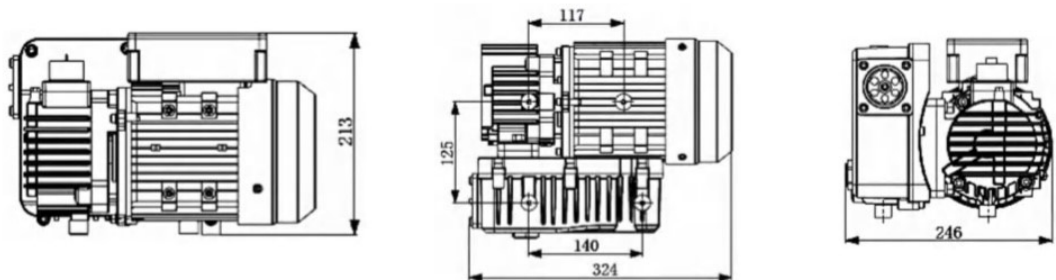

尺寸 (size) /mm	A	B	C	D	E	F	G	H
RA0040F	650	150	330	195	270	220	300	280
RA0063F	650	150	325	295	290	285	430	295
RA0100F	720	180	350	295	290	285	430	295

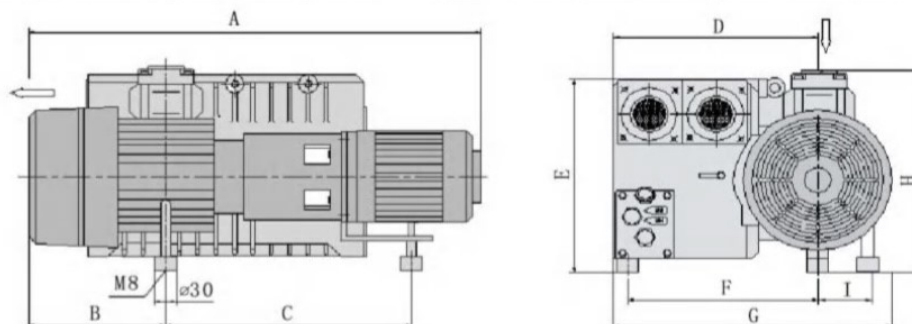

单级油旋片泵 SINGLE STAGE OIL ROTARY VANE VACUUM PUMP

RA0160/202/250/302D



型号/Model	单位/Unit	RA0160D		RA0202D		RA0250D		RA0302D	
		50HZ	60HZ	50HZ	60HZ	50HZ	60HZ	50HZ	60HZ
抽速 Nominal Capacity	m ³ /h	160	190	200	240	250	300	300	360
极限真空 Ultimate pressure	mbar	0.5		0.5		0.5		0.5	
电机功率 Motor Power	KW	4		4.5		5.5		7.5	
电机转速 motor speed	rpm	1450	1750	1450	1750	1450	1750	1450	1750
噪音等级 Sound level	dB	72		72		74		74	
用油量 Oil filling	L	5.0		5.0		6.5		6.5	
接口尺寸 Interface Size		G2		G2		G2		G2	
重量 Weight	KG	140		140		190		190	

尺寸/Size

尺寸 (size) /mm	A	B	C	D	E	F	G	H	I	J	K	L	M	N	P
RA0160D	835	855	495	435	25	425	310	225	345	15	240	M10	G2	35	420
RA0202D	835	855	495	435	25	425	310	225	345	15	240	M10	G2	35	420
RA0250D	856	980	560	440	30	430	355	260	385	20	300	M10	G2	40	390
RA0302D	856	1010	560	440	37	430	355	260	385	27	300	M10	G2	40	390

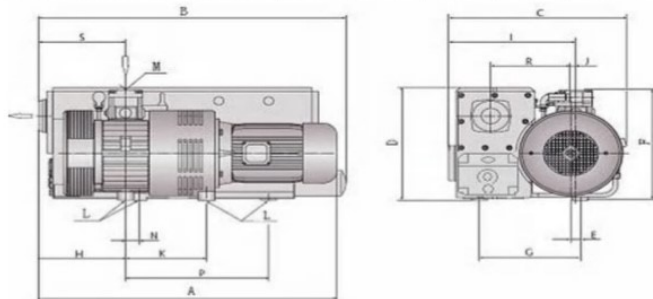

工作原理/Working principle:

油式旋片真空泵是根据旋转叶片原理工作的。
油封住间隙，润滑叶片，带走压缩热。滤油器用于清洗循环油。
排气过滤器把油和废气分开。

Typical applications:

Vacuum packaging and food processing, thermal forming, vacuum degassing, defoaming, concentration, vacuum drying, vacuum adsorption, and other processes

